

25G SFP28 Transceiver

MTRA-3E31A

Features

- Up to 10KM transmission distance
- Support Multi Rate 9.8304~25.78125Gbps
- 1310nm DFB and PIN receiver
- 25GAUI C2M electrical interface
- 2-wire interface for integrated Digital Diagnostic monitoring
- SFP+ MSA package with duplex LC connectors
- Hot pluggable
- Very low EMI and excellent ESD protection
- +3.3V power supply
- Power consumption less than 1.0 W
- Operating case temperature: -40~85°C

Applications

- 25Gbps Ethernet
- CPRI/ecpri

Compliance

- Compliant with IEEE 802.3cc
- Compliant with FCC 47 CFR Part 15, Class B
- Compliant with MSA SFF-8472
- Compliant with MSA SFF-8431



Description

The HG Genuine MTRA-3E31A is a high performance, cost effective modules, which is supporting Multi Rate 9.83~25.78Gbps, and transmission distance up to 10km on SM fiber. The transceiver consists of two sections: The transmitter section incorporates a 1310nm DFB Laser, a driver and a CDR. The receiver section consists of a PIN photodiode integrated with a trans-impedance preamplifier (TIA), a Limiting Amplifier and CDR. The module is hot pluggable with a 20-pin connector. The high-speed electrical interface is base on low voltage logic, with nominal 100 Ohms differential impedance and AC coupled in the module.

The optical output can be disabled by the LVTTTL logic high-level input on TX_DIS pin. Transmit Fault (Tx_Fault) is provided to indicate that the module transmitter has detected a fault condition related to laser operation or safety. Loss of signal (RX_LOS) output is provided to indicate the loss of an input optical signal in receiver.

A serial EEPROM in the transceiver allows the user to access transceiver monitoring and configuration data via the 2-wire SFP Management Interface. Digital diagnostics function are available via a 2-wire serial interface, as specified in SFF-8472.

Absolute Maximum Ratings

Table1-Absolute Maximum Ratings

Parameter	Symbol	Min.	Max.	Unit
Storage Temperature	T _s	-40	85	°C
Supply Voltage (no damaged)	V _{CC3}	-0.5	3.63	V
Relative Humidity(non-condensing)	RH		85	%
RX Input OMA Power	P _{max}		3	dBm

Recommended Operating Conditions

Table2-Recommended Operating Conditions

Parameter	Symbol	Min.	Typical	Max.	Unit
Operating Case Temperature	T _c	-40	25	85	°C
Power Supply Voltage	V _{CC3}	3.135	3.3	3.465	V
	I _{CC3}			300	mA
Maximum sustained peak Current(<500ms)				330	mA
Maximum Instantaneous peak current(<50us)				400	mA
Electro-Static discharge	ESD	1000	-	-	V
Power Dissipation	P _D			1	W
Data Rate(NRZ)		9.8304	24.33024	25.78125	Gbps
Transmission Distance				10	Km

Optical, Electrical Characteristic

MTRA-3E31A (1310nm DFB and PIN, 10Km)

Tested under recommended operating conditions, unless otherwise noted

Table3-Transmitter Operating Characteristic-Optical, Electrical

Parameter	Symbol	Min.	Typical	Max.	Unit	Note
Optical Interface Parameters						
Centre Wavelength	λ _c	1295	1310	1325	nm	
Side Mode Suppression Ratio	SMSR	30			dB	
Spectral Width(20dB)	P _m	-	-	1	nm	
Laser Off Power	P _{off}			-30	dBm	
Average Optical Power	P _{avg}	-7		2	dBm	
OMA	P _{OMA}	-4		2.2	dBm	
Extinction Ratio	ER	3.5			dB	
Transmitter Dispersion Penalty				2.7	dB	

Relative Intensity Noise	Rin			-130	dB/Hz		
Optical Return Loss Tolerance		-		20	dB		
Operating Data Rate		9.8304	24.33024	25.78125	Gbps	Note1	
Optical Eye Mask Margin		>5%					Note 2
Optical Eye Mask Definition {X1,X2,X3,Y1,Y2,Y3}, 25Gbase_LR		{0.31, 0.4, 0.45, 0.34, 0.38, 0.4}					
Electrical Interface Parameters							
Tx Input Diff Voltage	VI	180	500	900	mV		
Eye Height @ BER=1e-15	EH15	95			mV		
Eye width @ BER=1e-15	EW15	0.46			UI		
Tx Fault	VOL			0.4	V	At 0.7mA	
	VOH	VccT-0.4				Note3	

Notes:

[1] Under CDR bypass mode, 9.8304Gbps, 10.1376Gbps, 10.3125Gbps compatibility

[2] 500 consecutive snapshots at typical rate and room temperature, PRBS31 NRZ,

25GBase_LR mask and filter, Hit ratio meet the standard 5E-5 for 24.33024Gbps, 25.78125Gbps

10GBase_LR mask and filter, Hit ratio meet the standard 1E-12 for 9.8304Gbps, 10.1376Gbps, 10.3125Gbps

[3] Measured with a 4.7k Ohm load pulled up to Vcc

Table4-Receiver Operating Characteristic-Optical, Electrical

Parameter	Symbol	Min.	Typ.	Max.	Unit	Note	
Optical Interface Parameters							
Center Wavelength	λ_r	1295	1310	1325	nm		
Receiver Stress Sensitivity, OMA				-9.5	dBm		
Receiver Sensitivity, Average Power				-13.3	dBm	Note 1	
Receiver Sensitivity, OMA				-12	dBm	Note 1	
LOS Assert	LosA	-30			dBm		
LOS Dessert	LosD			-16	dBm		
LOS Hysteresis	LosH	0.5			dB		
Saturation Input Power	Pin	2			dBm		
Receiver Reflectance				-26	dB		
Electrical Interface Parameters							
Operating Data Rate		9.8304	24.33024	25.78125	Gbps	Note 2	
Rx Output Diff Voltage	Vo	450	600	750	mV	Note 3	
Rx Output Rise and Fall Time	Tr/Tf	9.5			ps	20% to 80%	
Eye Height @ BER=1e-15	EH15	228			mV	Note 3	
Eye Width @ BER=1e-15	EW15	0.57			UI	Note 3	
Vertical Eye Closure	Vc			5.5	dB	Note 3	
RX LOS enable/disable		Enable					Note4
LOS Criterion		Average power					

Notes:

[1] Measured with 25.78125Gb/s, 24.33024Gb/s, PRBS-31 NRZ, ER>3.5dB, 1295~1325nm, BER<5E-5

Measured with 9.8304Gb/s,10.1376Gb/s,10.3125Gb/s, PRBS-31 NRZ, ER>3.5dB, 1295~1325nm, BER<1E-12
 [2] Under CDR bypass mode, 9.8304Gb/s, 10.1376Gb/s, 10.3125Gb/s compatibility
 [3] PRBS31 Pattern with Default Emphasis 1dB at 24.33024Gbps and 25.78125Gbps; when data rate turns to 9.8304Gbps, 10.1376Gbps, 10.3125Gbps application, the output emphasis automatically change to 0 dB.
 [4] Rx Output Squelched on LOS

Table5-Digital Diagnostic Functions

Parameter	Symbol	Min.	Max.	Unit	Note
Temperature monitor absolute error	DMI_Temp	-3	3	°C	Over operating temp
Laser power monitor absolute error	DMI_TX	-3	3	dB	
RX power monitor absolute error	DMI_RX	-3	3	dB	
Supply voltage monitor absolute error	DMI_VCC	-0.1	0.1	V	
Bias current monitor absolute error	DMI_Ibias	-10	10	%	

Table6-Control and Status I/O Timing Characteristics

Parameter	Symbol	Min.	Max.	Unit	Note
TX Disable Assert Time	t_off		100	µs	Note1
TX Disable Negate Time	t_on		2	ms	Note2
Time to initialize including reset of TX_Fault	t_init		300	ms	Note3
TX Fault Assert Time	t_fault		1	ms	Note4
Tx_Fault Reset	t_reset	10		µs	Note5
LOS Assert Time	t_loss_on		100	µs	Note6
LOS Deassert Time	t_loss_off		100	µs	Note7
Rate-Select Change Time	t_ratesel		100	ms	Note8
Rx LOS Assert Delay	t_los_on		100	us	
Rx LOS Negate Delay	t_los_off		100	us	
Time To Clock Re_locked	t_clk_lock		20	ms	

Notes:

- [1] Time from rising edge of TX Disable to when the optical output falls below 10% of nominal
- [2] Time from falling edge of TX Disable to when the modulated optical output rises above 90% of nominal
- [3] From power on or negation of TX Fault using TX Disable
- [4] Time from fault to TX fault on
- [5] Time TX Disable must be held high to reset TX_fault
- [6] Time from LOS state to RX LOS assert
- [7] Time from non-LOS state to RX LOS deassert.
- [8] Time from rising or falling edge of Rate Select input until receiver bandwidth is in conformance with appropriate specification

Table7-IIC 2-wire specification

Parameter	Symbol	Min.	Max.	Unit	Note
Clock frequency	f_scl	0	400	KHz	Note1
Clock pulse width low	t_LOW	1.3	-	us	
Clock pulse width high	t_HIGH	0.6	-	us	
START Hold Time	t_HD:STA	0.6	-	us	
START Set-up Time	t_SU:STA	0.6	-	μs	
Data In Hold Time	t_HD:DAT	0	-	ns	
Data In Set-up Time	t_SU:DAT	100	-	ns	
Input Rise Time(100KHz) From (V _{IL,MAX} - 0.15) to (V _{IH,MIN} + 0.15)	T _{r,100}	-	1000	ns	
Input Rise Time(400KHz) From (V _{IL,MAX} - 0.15) to (V _{IH,MIN} + 0.15)	T _{r,400}	-	300	ns	
Input Fall Time(100KHz) From (V _{IH,MIN} + 0.15) to (V _{IL,MAX} - 0.15)	T _{f,100}	-	300	ns	
Input Fall Time(400KHz) From (V _{IH,MIN} + 0.15) to (V _{IL,MAX} - 0.15)	T _{f,400}	-	300	ns	
STOP Set-up Time	t_SU:STO	0.6	-	us	
Time bus free before new transmission can start	t _{BUF}	20	-	us	
Time to initialize	t_init		300	ms	Note2
Clock stretching	T _{clock_hold}		500	us	Note3\ Note4
Complete Single or Sequential Write up to 4 Byte	t _{WR}	-	40	ms	
Complete Sequential Write of 5-8 Byte	t _{WR}	-	80	ms	
Endurance (Write Cycles)		10k	-	cycle	

Notes:

[1] SFP28 module clock frequency must satisfied 0~400kHz;

[2] The time means from power up to module work normally;

[3] Maximum time module may hold the SCL line low before continuing with a read or write operation;

[4] If module support clock stretching, should meet the specification; if module don't support clock stretching, don't care .

Reliability Test Definitions and Distributions

Table8-Reliability Test Definitions and Distributions

Group	Test	Reference	Condition	SS ^[1]	C ^[2]
Mechanical Integrity	Mechanical shock	MIL-STD-883E Method 2002.4	5 times/axis, 6 axes; 500G, 1.0ms	11	0
	Vibration	MIL-STD-883E Method 2007.3	20G, (20-2,000) Hz, 4 min/cycle, 4 cycles/axial direction, 3 axial direction	11	0
Endurance	Accelerated Aging	GR-468-Core 3.3.3.1	85°C(Ambient Temp.) Vcc=3.3V, 2,000hrs required	22	0
	High temperature Storage	GR-468-Core Issue 2, Section 3.3.2.1	85 °C (Ambient Temp.), 2000hrs	11	0
	Low temperature Storage	GR-468-Core Issue 2, Section 3.3.2.1	-40°C (Ambient Temp.), 72 hours	11	0
	Temperature Cycles	GR-468-Core Issue 2, Section 3.3.2.2 or MIL-STD-883C Method 1010.8	-40°C/85°C, 100 cycles (CO environment), 500 cycles (UNC environment)	11	0
	Damp Heat	GR-468-CORE 3.3.2.3	85°C/85%RH, 500h	11	0
	Cyclic moisture resistance	MIL-STD-883E Method 1004.7	No preconditioning. Normal operating conditions. Ramp Time below zero to min storage temp should be rapid or with fast ramp time. Minimum of 20 cycles with 10 sub-cycles. Active Components and Modules. 20 cycles, w/ 5 sub-cycles.	11	0

Special Test	ESD threshold	GR-468-CORE , SFP+ MSA INF-8431、 JESD22-A114 etc.	The modules should meet ESD threshold value requirement which defined in GR-468-CORE , as well as in MSA documents . for example, high speed interface, XFP XFI pin, Serdes should meet HBM 500v ESD requirement , the other interface should meet above 2K V HBM ESD level. In terms of 8Kv package contact ESD test and air discharge ESD 15KV test, it is allowed that bit-error occurring during the test, but the bit-error shall be able to recover automatically.	6	0
---------------------	---------------	---	--	---	---

Note:

[1] SS: Sample Size;

[2] C: Maximum number of failure allowed in the test.

Pin-out Definitions

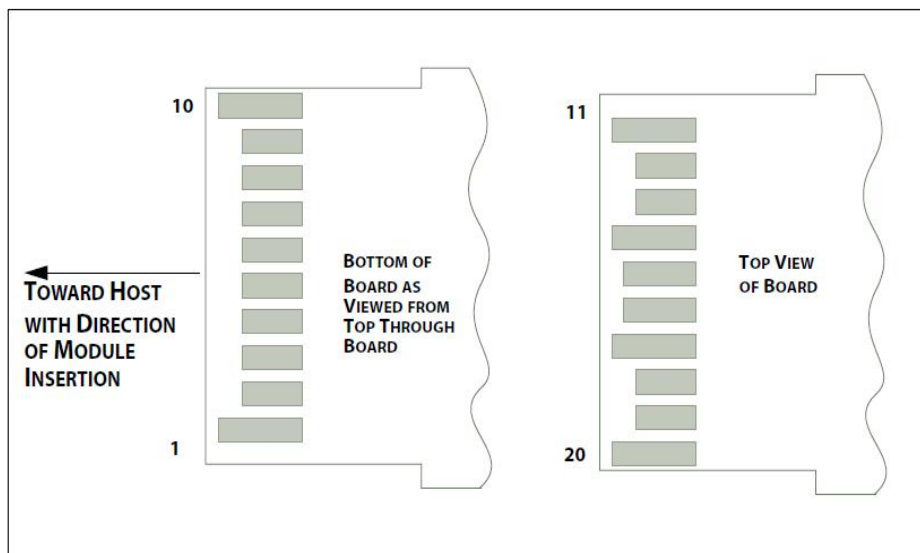

Figure1

Table9-Pin Function Definitions

Pin	Logic	Symbol	Name/Description	Note
1		VeeT	Module Transmitter Ground	Note1
2	LVTTL-O	TX_Fault	Module Transmitter Fault	Note2
3	LVTTL-I	TX_Disable	Transmitter Disable; Turns off transmitter laser output	Note3

4	LVTTTL-I/O	SDA	2-wire Serial Interface Data Line (Same as MOD-DEF2 as defined in the INF-8074i)	Note4
5	LVTTTL-I/O	SCL	2-wire Serial Interface Clock (Same as MOD-DEF1 as defined in the INF-8074i)	Note4
6		MOD_ABS	Module Absent, connected to VeeT or VeeR in the module	Note5
7	LVTTTL-I	RS0	Rate Select 0, optionally controls SFP+ module receiver.	Note6
8	LVTTTL-O	RX_LOS	Receiver Loss of Signal Indication (In FC designated as RX_LOS, in SONET designated as LOS, and in Ethernet designated at Signal Detect)	Note2
9	LVTTTL-I	RS1	Rate Select 1, optionally controls SFP+ module transmitter	Note6
10		VeeR	Module Receiver Ground	Note1
11		VeeR	Module Receiver Ground	Note1
12	CML-O	RD-	Receiver Inverted Data Output	
13	CML-O	RD+	Receiver Non-Inverted Data Output	
14		VeeR	Module Receiver Ground	Note1
15		VccR	Module Receiver 3.3 V Supply	
16		VccT	Module Transmitter 3.3 V Supply	
17		VeeT	Module Transmitter Ground	Note1
18	CML-I	TD+	Transmitter Non-Inverted Data Input	
19	CML-I	TD-	Transmitter Inverted Data Input	
20		VeeT	Module Transmitter Ground	Note1

Notes:

- [1] The module signal ground pins, VeeR and VeeT, shall be isolated from the module case.
- [2] This pin is an open collector/drain output pin and shall be pulled up with 4.7k-10kohms to Host_Vcc on the host board. Pull ups can be connected to multiple power supplies, however the host board design shall ensure that no module pin has voltage exceeding module VccT/R + 0.5 V.
- [3] This pin is an open collector/drain input pin and shall be pulled up with 4.7k-10kohms to VccT in the module.
- [4] See SFF-8431 4.2 2-wire Electrical Specifications .
- [5] This pin shall be pulled up with 4.7k-10kohms to Host_Vcc on the host board.
- [6] RS0 and RS1 are module inputs and are pulled low to VeeT with 30 k Ω resis-tors in the module.

Block Diagram of Transceiver

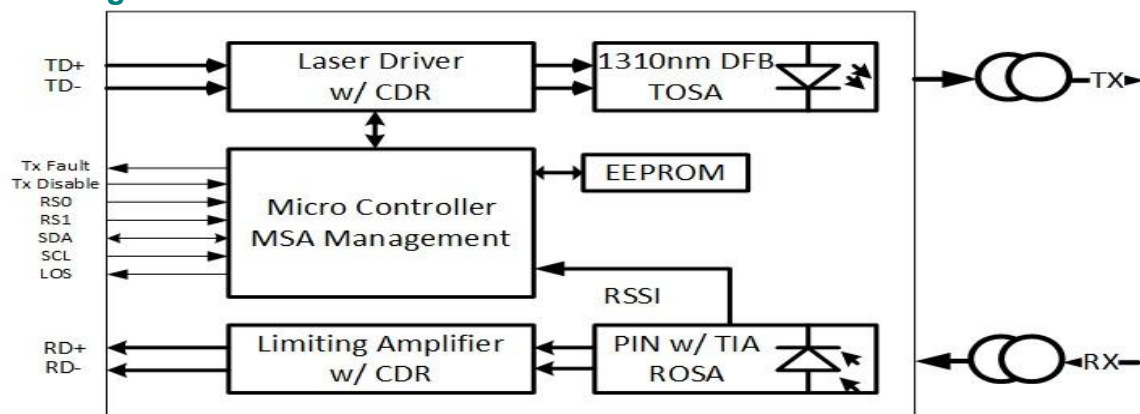

Figure2

<Transmitter Section>:

The transmitter converts 25.78Gbit/s serial PECL or CML electrical data into serial optical data compliant with the 25G Ethernet. An open collector compatible Transmit Disable (Tx_Dis) is provided. A logic “1,” or no connection on this pin will disable the laser from transmitting. A logic “0” on this pin provides normal operation. The transmitter has an internal automatic power control loop (APC) to ensure constant optical power output across supply voltage and temperature variations. An open collector compatible Transmit Fault (Tx_Fault) is provided. TX_Fault is a module output contact that when high, indicates that the module transmitter has detected a fault condition related to laser operation or safety. The TX_Fault output contact is an open drain/collector and shall be pulled up to the Vcc_Host in the host with a resistor in the range 4.7-10 kΩ. TX_Disable is a module input contact. When TX_Disable is asserted high or left open, the SFP+ module transmitter output shall be turned off. This contact shall be pulled up to VccT with a 4.7 kΩ to 10 kΩ resistor. Per the requirements of performance, internal clock and data recovery circuits (CDR) are present on electrical input of this transceiver module.

<Receiver Section>:

The receiver converts 25.78Gbit/s serial optical data into serial PECL/CML electrical data. An open collector compatible Loss of Signal is provided. Rx_LOS when high indicates an optical signal level below that specified in the relevant standard. The Rx_LOS contact is an open drain/collector output and shall be pulled up to Vcc_Host in the host with a resistor in the range 4.7-10 kΩ, or with an active termination. The Rx_LOS signal is intended as a preliminary indication to the system in which the SFP+ is installed that the received signal strength is below the specified range. Such an indication typically points to non-installed cables, broken cables, or a disabled, failing or a powered off transmitter at the far end of the cable. Per the requirements of performance, internal clock and data recovery circuits (CDR) are present on electrical output of this transceiver module.

<TX Equalization Control>:

Tx input equalization control can be accessed through 2-wire serial interface at byte address 114(A2h). Tx input equalization control for 25GE is located at the upper 4 bits of byte 114 (A2h).

<RX Emphasis Control>:

Rx output emphasis control can be accessed through 2-wire serial interface at byte address 115(A2h). Rx output emphasis control for 25GE is located at the upper 4 bits of byte 115 (A2h).

<Rate Selection>:

The Data Rate or Retimer/CDR status could be configured by physical Interface RS0, RS1 pin or the mapping register (110,118 byte bit3 (A2h)) through 2-wire communication interface. Configuration and Rate performance could reference the table10 as below.

Table10-Rate selection

Logic OR of RS0 pin and RS0 bit	Logic OR of RS1 pin and RS1 bit	Receiver retimer/CDR	Transmitter retimer/CDR	Rate
Low/0	Low/0	CDR Bypass	CDR Bypass	Tx and Rx: 9.8304Gbps, 10.1376Gbps or 10.3125Gbps
Low/0	High/1	CDR Bypass	CDR Lock at High Data Rate	Tx: 24.33024Gbps or 25.78125Gbps. Module auto detect data rate and CDR lock accordingly. Rx: 9.8304Gbps, 10.1376Gbps or 10.3125Gbps
High/1	Low/0	CDR Lock at High Data Rate	CDR Bypass	Tx: 9.8304Gbps, 10.1376Gbps or 10.3125Gbps Rx: 24.33024Gbps or 25.78125Gbps. Module auto detect data rate and CDR lock accordingly.
High/1	High/1	CDR Lock at High Data Rate	CDR Lock at High Data Rate	Defaults Tx and Rx: 24.33024Gbps or 25.78125Gbps. Module auto detect data rate and CDR lock accordingly.

Recommended Interface Circuit

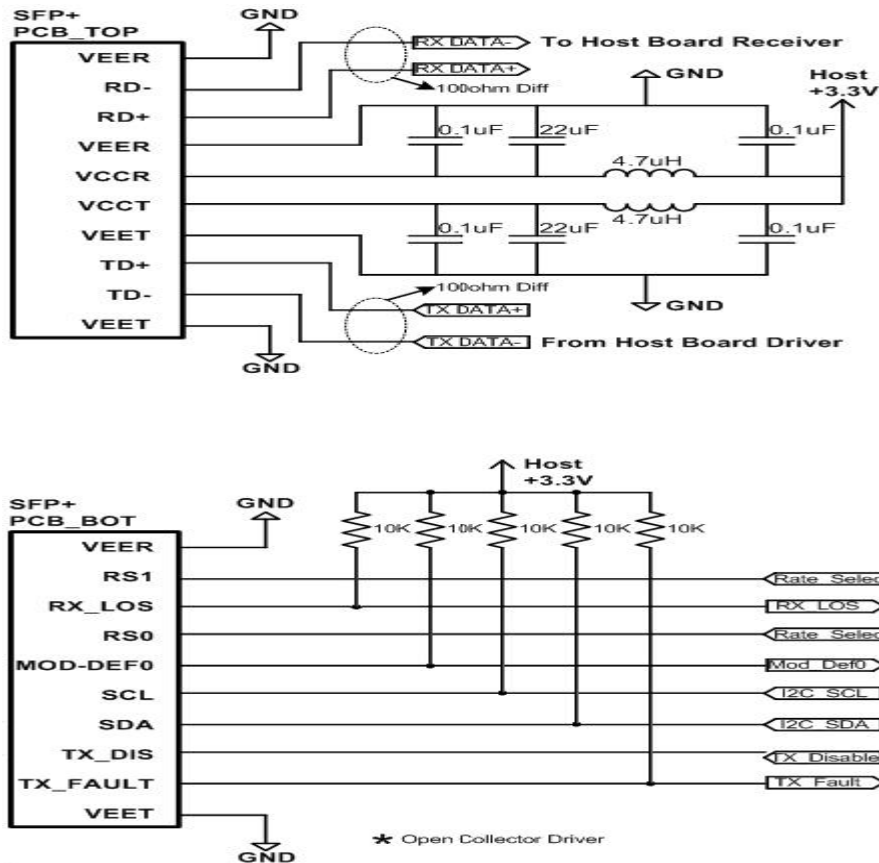

Figure3

Dimensions

Unit:mm

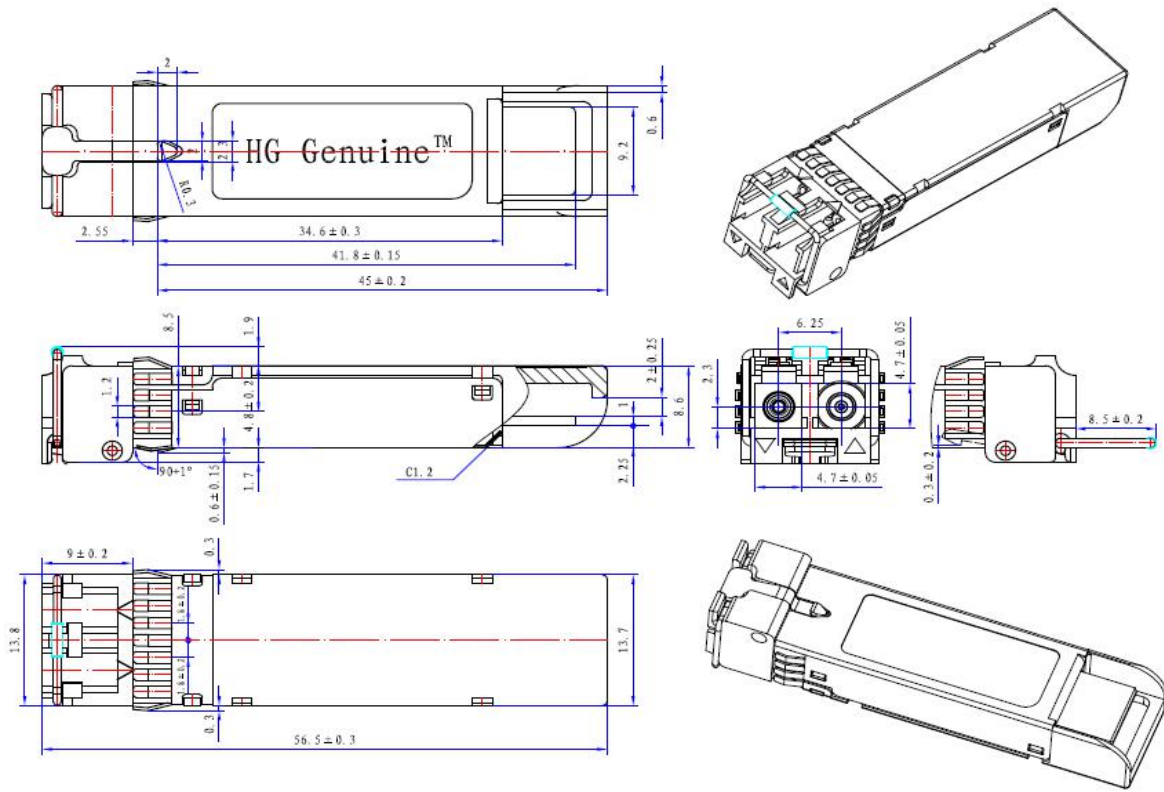

Figure4

Digital Diagnostic Memory Map

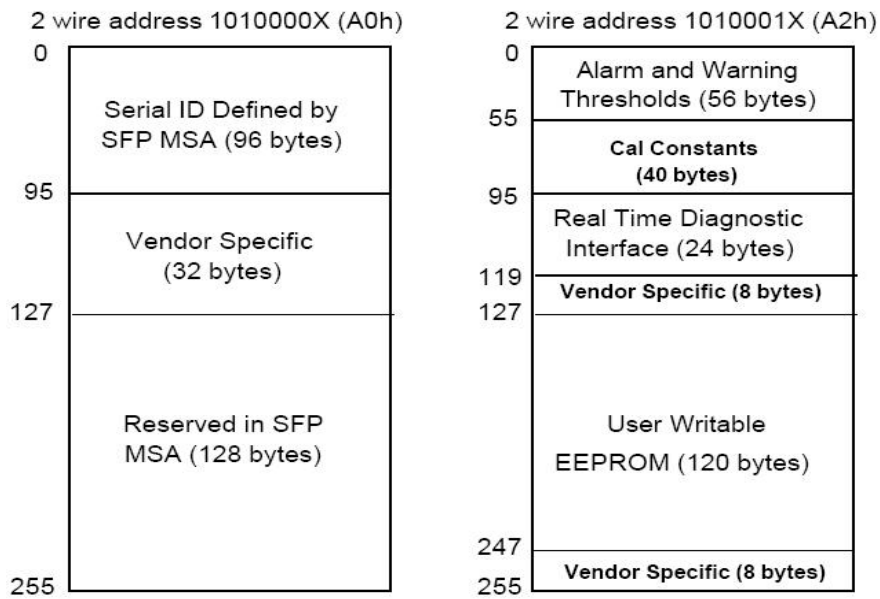

Figure5

EEPROM Information

The SFP MSA defines a 256-byte memory map in EEPROM describing the transceiver's capabilities, standard interfaces, manufacturer, and other information, which is accessible over a 2-wire serial interface at the 8-bit address 1010000X (A0h). The memory contents refer to Table 11.

Table 11-EEPROM Serial ID Memory Contents (A0h)

Addr.	Field Size	Name of Field	Hex	Description
	(Bytes)			
0	1	Identifier	03	SFP
1	1	Ext. Identifier	04	SFP function is defined by serial ID only
2	1	Connector	07	LC Connector
3-10	8	Transceiver	00 00 00 00 00 00 00 00	10G Ethernet Compliance Codes
11	1	Encoding	03	NRZ
12	1	BR, Nominal	FF	255*100MBd
13	1	Rate Identifier	0D	Unspecified
14	1	Length (9um) km	0A	Transceiver transmit distance, 10km
15	1	Length (9um) 100m	64	Transceiver transmit distance, 100*100m
16	1	Length (50um) 10m	00	Transceiver transmit distance
17	1	Length (62.5um) 10m	00	Transceiver transmit distance
18	1	Length (Copper)	00	Not compliant
19	1	Length (50um OM3)	00	Not compliant
20-35	16	Vendor name	48 47 20 47 45 4E 55 49 4E 45 20 20 20 20 20 20	"HG GENUINE" Vendor Name(ASCII)
36	1	Reserved	03	25GBASE-LR
37-39	3	Vendor OUI	00 00 00	
40-55	16	Vendor PN	4D 54 52 41 2D 33 45 33 31 41 20 20 20 20 20 20	"MTRA-3E31A" Part No.(ASCII)
56-59	4	Vendor rev	31 2E 30 20	"1.0" (ASCII)
60-61	2	Wavelength	05 1E	Transceiver wavelength
62	1	Reserved	00	
63	1	CC_BASE	15	Check code for Base ID Fields
64-65	2	Options	0A 3A	a conventional uncooled laser Power Level 2 a conventional limiting output the transceiver has an internal retimer or CDR TX_DISABLE TX_FAULT Rx_LOS RATE_SELECT
66	1	BR,MAX	67	103%, 25.75Gbps
67	1	BR,MIN	00	

68-83	16	Vendor SN	SN(Variable)	Serial Number of transceiver(ASCII).
84-91	8	Date code	DC(Variable)	Manufactory Date Code.
92	1	Diagnostic Monitoring Type	68	Digital diagnostic monitoring implemented, “internally calibrated” is implemented
93	1	Enhanced Options	F8	Alarm/warning flags soft TX_DISABLE soft TX_FAULT soft RX_LOS soft RATE_SELECT
94	1	SFF_8472 Compliance	08	Includes functionality described in Rev12.0 SFF-8472
95	1	CC_EXT	13(Variable)	Check sum for Extended ID Field.
96-127	32	Vendor Specific	Read only	Depends on customer information Filled by zero
128-255	128	Reserved	Read only	Filled by zero

Table12-DDM Alarm & warning threshold(A2h)

Addr.	Field Size	Name of Field	Description
	(Bytes)		
00-01	2	Temperature High Alarm	95°C
02-03	2	Temperature Low Alarm	-50°C
04-05	2	Temperature High Warning	85°C
06-07	2	Temperature Low Warning	-40°C
08-09	2	Vcc High Alarm	3.63V
10-11	2	Vcc Low Alarm	2.97V
12-13	2	Vcc High Warning	3.465V
14-15	2	Vcc Low Warning	3.135V
16-17	2	Bias High Alarm	90mA
18-19	2	Bias Low Alarm	5mA
20-21	2	Bias High Warning	80mA
22-23	2	Bias Low Warning	10mA
24-25	2	TX Power High Alarm	5dBm
26-27	2	TX Power Low Alarm	-10dBm
28-29	2	TX Power High Warning	2dBm
30-31	2	TX Power Low Warning	-7dBm
32-33	2	RX Power High Alarm	5dBm
34-35	2	RX Power Low Alarm	-16.3dBm
36-37	2	RX Power High Warning	2dBm
38-39	2	RX Power Low Warning	-13.3dBm

Regulatory Compliance

Table13-Regulatory Compliance

Feature		Reference	Performance
Electrostatic discharge (ESD)		IEC/EN 61000-4-2	Compatible with standards
Electromagnetic Interference (EMI)		FCC Part 15 Class B EN 55022 Class B (CISPR 22A)	Compatible with standards
Laser Eye Safety		FDA 21CFR 1040.10, 1040.11 IEC/EN 60825-1, 2	Class 1 laser product
Component Recognition		IEC/EN 60950 , UL	Compatible with standards
ROHS		2002/95/EC	Compatible with standards
EMC		EN61000-3	Compatible with standards
Safety regulation requirement	UL	UL60950-1	Compatible with standards
	TUV	IEC/EN60950-1, IEC/EN60825-1, IEC/EN60825-2;	Compatible with standards
	FDA	21 CFR 1040.10 & 1040.11	Compatible with standards

--Caution - use of controls or adjustment or performance of procedures other than those specified herein may result in hazardous radiation exposure.

Ordering Information

Table14- Ordering Information

Part No.	Specification								
	Pack	Rate	Tx	Pout	Rx	Sens_ OMA	Top	Reach	Others
MTRA-3E31A	SFP28	25.78	1310nm DFB	-7~2 dBm	PIN	<-12dBm	-40~85℃	10km	DDMRoHS

Contact Information

Wuhan Huagong Genuine Optics Technology Co., Ltd

Address: Science & Technology Region of HUST, Donghu High-Tech Zone
Wuhan, Hubei Province, 430223, China

- Tel: +86-27-87180102
- Fax: +86-27-87180220

Email: market@genuine-opto.com

Website: <http://www.genuine-opto.com>

Statement

HG Genuine possesses the authority for ultimate explanation of all information contained in this document, which is subject to change without prior notice. All the information was obtained in specific environments; and HG Genuine will not be responsible for verifying the products performance in customers' operating environments, neither liable for the performance of users' products. All information contained is only for the users' reference and shall not be considered as warranted characteristics. HG Genuine will not be liable for damages arising directly or indirectly from any use of the information contained in this document.

Publishing Date: 2018-12-18

Copyright ©HG Genuine

All Right Reserved

www.sfp.by